

IV. Practices and Procedures

A. Administrative Controls

1. Biohazard Warning Signs and Posting

Each laboratory must have a room sign that provides safety information to visitors and service personnel. Room signs must contain designations for all laboratory hazards in use within the laboratory (carcinogens, acutely toxic agents, reproductive hazards, biohazards, radioactive materials, lasers and magnetic fields). Complete the form in Appendix I of the University of Pennsylvania Chemical Hygiene Plan to request a room sign.

All areas and laboratories that contain biohazardous agents must be posted with the biohazard warning sign (Figure 1). The background must be red/orange in color with a black universal biohazard symbol and black lettering.



Figure 1

All areas and laboratories that contain biohazardous or toxic agents must be posted with signs stating, "EATING, DRINKING, SMOKING AND APPLYING COSMETICS ARE PROHIBITED IN THIS AREA."

All equipment (centrifuges, water baths, cryogenic freezers, incubators, etc.) that comes in contact with biohazardous materials must be labeled with the universal biohazard symbol.

2. Biosafety Levels

The essential elements of the four Biosafety levels for activities involving infectious microorganisms are summarized in Table 1. The levels are designated in ascending order, by degree of protection provided to personnel, the environment and the community. In general, Risk Group 1 agents are handled at Biosafety Level 1, Risk Group 2 agents at Biosafety Level 2 and so on.

There are NO Biosafety Level 4 laboratories at Penn. Agents requiring this level of containment may not be brought to Penn's campus.

3. Vertebrate Animal Biosafety Levels

There are four animal Biosafety levels for experiments on animals infected with agents that produce or may produce human infection. They are summarized in Table 2. As with Biosafety Levels, increasing levels of protection to personnel and the environment are provided as the order ascends.

There are NO Animal Biosafety Level 4 facilities at Penn. Animal work requiring this level of containment may not occur on Penn's campus.

4. Medical Surveillance

A medical surveillance program will be provided through Occupational Medicine at HUP for those personnel having substantial direct animal contact.

A medical surveillance program will be provided through Occupational Medicine for those personnel who are occupationally at-risk of exposure to bloodborne pathogens. The program will include free hepatitis B vaccine, post-exposure evaluation and follow-up. For a more detailed explanation of this program, consult the University's Exposure Control Plan.

Designated personnel (Principal Investigators / Area Supervisors) are responsible to conduct a risk assessment for their area to determine the risk for nosocomial or occupational transmission of M. tuberculosis and implement an appropriate TB infection control plan. See Appendix D of the University of Pennsylvania Exposure Control Plan, describing a Tuberculosis (TB) Infection Control Plan.

Vaccines for which the benefits (levels of antibody considered to be protective) clearly exceed the risk (local or systemic reactions) will be offered to all clearly identified at-risk personnel, because immunoprophylaxis may provide an additional level of protection. It is the Principal Investigator's responsibility to ensure that laboratory personnel who work in Biosafety Level 2 or Biosafety Level 3 facilities receive the appropriate immunizations or tests for the agents handled or potentially present in the laboratory (e.g. hepatitis B vaccine, Rabies vaccine, TB skin test, Vaccinia (smallpox) vaccine, etc.) and periodic testing as recommended for the agent(s) being handled. Baseline serum samples may be collected as appropriate. Additional serum specimens may be periodically collected, depending on the agents handled or the function of the laboratory.

For more information, contact EHRS at (215) 898-4453.

B. Engineering Controls

1. Biological Safety Cabinets

BSCs are designed to contain aerosols generated during work with infectious material through the use of laminar airflow and high efficiency particulate air (HEPA) filtration. All personnel must develop proficient lab technique before working with infectious materials in a BSC. Three types of BSCs (Class I, II and III) are used in microbiological laboratories.

The Class I BSC is suitable for work involving low to moderate risk agents, where there is a need for containment, but not for product protection. It provides protection to personnel and the environment from contaminants within the cabinet. The Class I BSC does not protect the product from "dirty" room air. It is similar in air movement to a chemical fume hood, but has a HEPA filter in the exhaust system to protect the environment. In many cases Class I BSCs are used specifically to enclose equipment (e.g., centrifuges, harvesting equipment or small fermenters), or procedures (e.g. cage dumping, aerating cultures or homogenizing tissues) with a potential to generate aerosols that may flow back into the room.

The Class II BSC protects the material being manipulated inside the cabinet (e.g., cell cultures, microbiological stocks) from external contamination as well as meeting requirements to protect personnel and the environment. There are four types of Class II BSCs: Type A1, Type A2, Type B1 and Type B2. The major differences between the three types may be found in the percent of air that is exhausted or recirculated, and the manner in which exhaust air is removed from the work area (EHRS does not support exhausting of Type A cabinets to the outside through a thimble connection to a building's exhaust system.)

Comparison of Class II Biosafety Cabinet Characteristics

BSC Class	Face Velocity	Airflow Pattern	Applications	
			Nonvolatile Toxic Chemicals and Radionuclides	Volatile Toxic Chemicals and Radionuclides
II, A1	75	70% recirculated to the cabinet work area through HEPA; 30% balance can be exhausted through HEPA back into the room or to the outside through a thimble unit	YES	NO
II, A2	100	Same as II, A, but plenums are under negative pressure to room; exhaust air is thimble-ducted to the outside through a HEPA filter	YES	YES [minute amounts (1)]
II, B1	100	Exhaust cabinet air must pass through a dedicated duct to the outside through a HEPA filter	YES	YES [minute amounts (1)]
II, B2	100	No recirculation; total exhaust to the outside through hard-duct and a HEPA filter	YES	YES (small amounts)
(1) In no circumstances should the chemical concentration				

approach the lower explosion limits of the compound.

The gas-tight Class III BSC, or glove box, provides the highest attainable level of protection to personnel, the environment and the product. It is the only cabinetry that provides a total physical barrier between the product and personnel. It is for use with *high-risk* biological agents and is used when absolute containment of highly infectious or hazardous material is required.

It is important to note that laminar flow clean benches must not be utilized for work with biohazardous or chemically hazardous agents. Clean benches provide product protection by ensuring that the product is exposed only to HEPA-filtered air. They do not provide protection to personnel or the ambient environment.

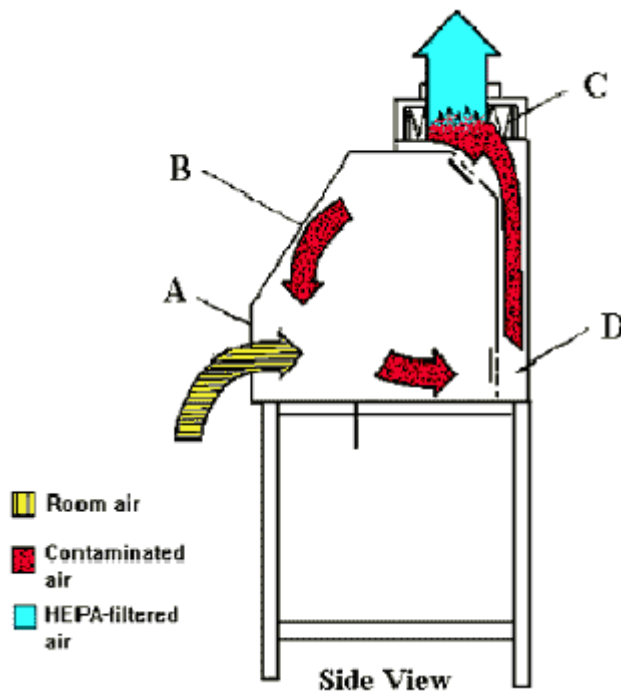

The Class I BSC

- A. front opening
- B. sash
- C. exhaust HEPA
- D. exhaust plenum

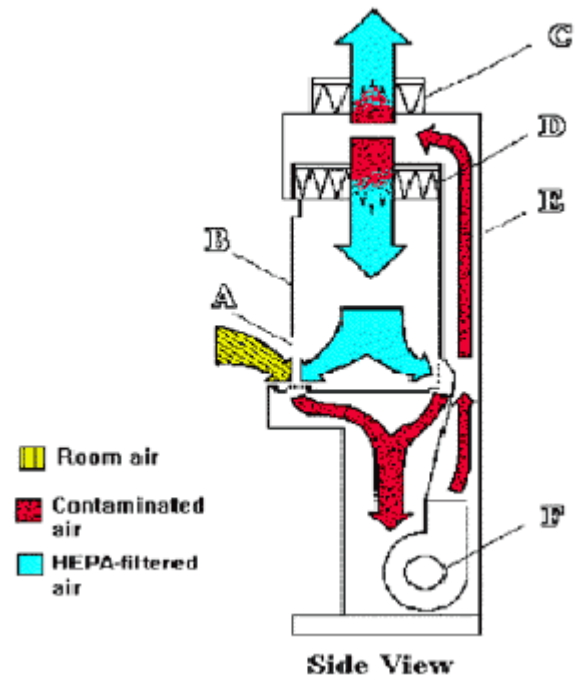

The Class II, Type A BSC

- A. front opening
- B. sash
- C. exhaust HEPA filter
- D. rear plenum
- E. supply HEPA filter
- F. blower

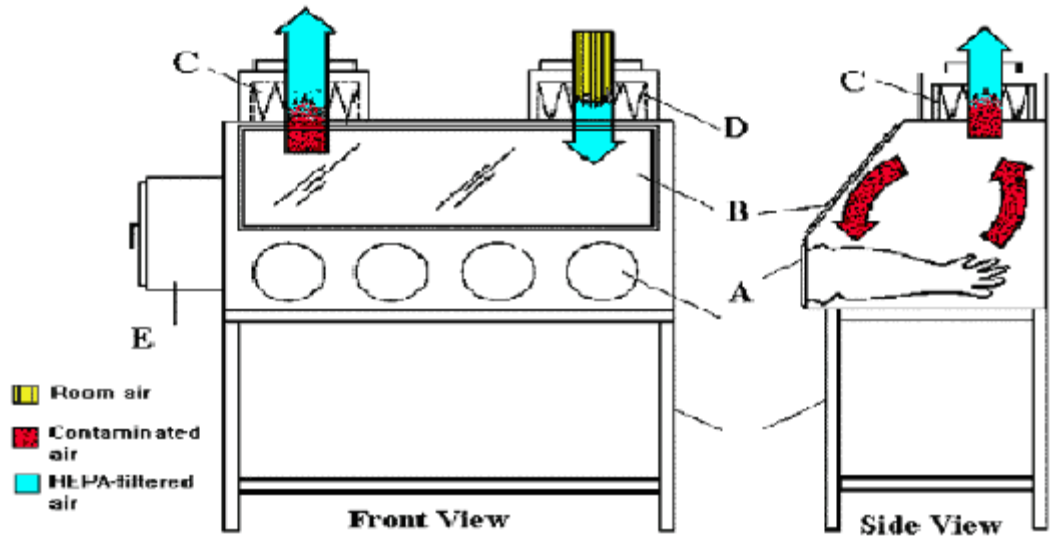

The Class III BSC

- A. glove ports with O-ring for attaching arm-length gloves to cabinet
- B. sash
- C. exhaust HEPA filter
- D. supply HEPA filter
- E. double-ended autoclave or pass-through box

a. Selection and Placement of Biosafety Cabinets in the Laboratory

Certain considerations must be met to ensure maximum effectiveness of these primary barriers. Contact EHRS prior to purchase of a biosafety cabinet to ensure you have selected an appropriate unit for the proposed usage. Contact your building administrator and EHRS to ensure proper installation and placement of a biosafety cabinet in your laboratory space.

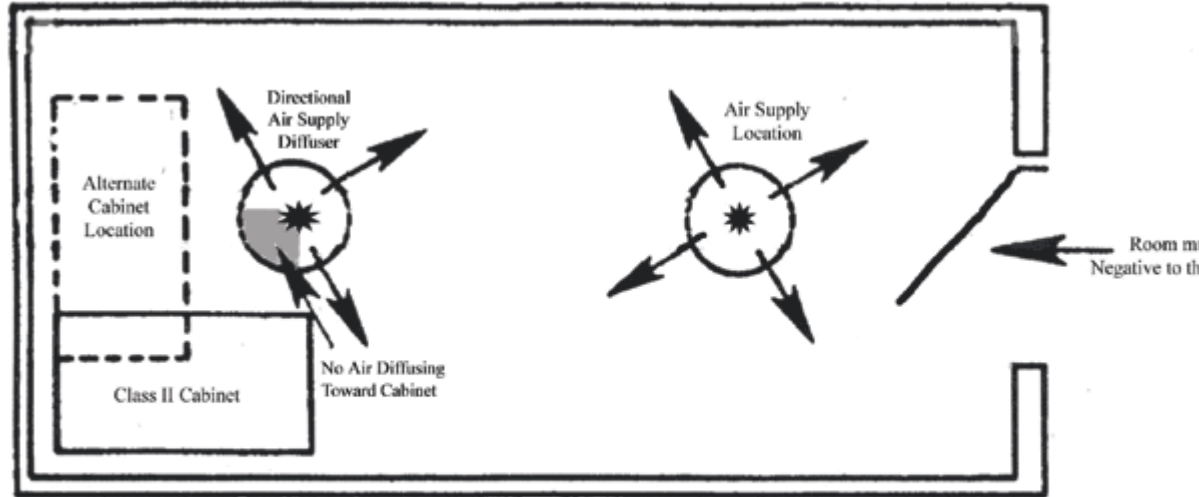

Recommended Laboratory Location for a Class II, Laminar Flow Biosafety Cabinet

Adequate clearance should be provided behind and on each side of the cabinet to allow easy access for maintenance, and to ensure that the air return to the laboratory is not hindered. The ideal location for the biological safety cabinet is remote from the entry (i.e., the rear of the laboratory away from traffic), since people walking parallel to the face of a BSC can disrupt the protective laminar flow air curtain. The air curtain created at the front of the cabinet is quite fragile, amounting to a nominal inward and downward velocity of 1 mph. A BSC should be located away from open windows, air supply registers, or laboratory equipment (e.g., centrifuges, vacuum pumps) that creates turbulence. Similarly, a BSC should not be located close to a chemical fume hood.

2. Other Safety Equipment

Safety equipment includes items for personal protection such as gloves, coats, gowns, shoe covers, boots, respirators, face shields, safety glasses or goggles. Personal protective equipment (PPE) must be used in combination with BSCs and other devices that contain biohazardous agents, animals or materials. When it is impractical to work in BSCs, PPE forms the primary barrier between personnel and infectious materials. Examples include certain animal studies, animal necropsy, agent production activities and activities relating to maintenance, service or support of the laboratory facility.

Other safety equipment such as safety centrifuge cups and safety blenders are enclosed containers designed to prevent aerosols from being released during centrifugation or homogenization of infectious material. Containment controls such as BSCs, safety centrifuge cups and blenders must be used for handling infectious agents that can be transmitted through the aerosol route of exposure.

For assistance in the selection of a BSC or other safety equipment, contact EHRS by phone (215-898-4453) or email.

For more information on PPE, a description of effective use of BSCs and information on other safety equipment may be found in the Recommended Work Practices section below.

C. Recommended Work Practices

1. Pipettes and Pipetting Aids

Pipettes are used for volumetric measurements and transfer of fluids that may contain infectious, toxic, corrosive or radioactive agents. Laboratory-associated infections have occurred from oral aspiration of infectious materials, mouth transfer via a contaminated finger and inhalation of aerosols. Exposure to aerosols may occur when liquid from a pipette is dropped onto the work surface, when cultures are mixed by pipetting, or when the last drop of an inoculum is blown out. A pipette may become a hazardous piece of equipment if improperly used. The safe pipetting techniques that follow are required to minimize the potential for exposure to biologically hazardous materials:

- Never mouth pipette. Always use a pipetting aid.
- If working with biohazardous or toxic fluid, confine pipetting operations to a biological safety cabinet.
- Always use cotton-plugged pipettes when pipetting biohazardous or toxic materials, even when safety pipetting aids are used.
- Do not prepare biohazardous materials by bubbling expiratory air through a liquid with a pipette.
- Do not forcibly expel biohazardous material out of a pipette.
- Never mix biohazardous or toxic material by suction and expulsion through a pipette.
- When pipetting, avoid accidental release of infectious droplets. Place a disinfectant soaked towel on the work surface and autoclave the towel after use.
- Use "to deliver" pipettes rather than those requiring "blowout".
- Do not discharge material from a pipette at a height. Whenever possible allow the discharge to run down the container wall.
- Place contaminated, reusable pipettes horizontally in a pan containing enough liquid disinfectant to completely cover them. Do not place pipettes vertically into

a cylinder. Autoclave the pan and pipettes as a unit before processing them as dirty glassware for reuse (see section D, Decontamination).

- Discard contaminated disposable pipettes in an appropriate sharps container. Autoclave the container when it is 2/3 to 3/4 full and dispose of as infectious waste.
- Place pans or sharps containers for contaminated pipettes inside the biological safety cabinet to minimize movement in and out of the BSC.

2. Syringes and Needles

Syringes and hypodermic needles are dangerous instruments. *The use of needles and syringes should be restricted to procedures for which there is no alternative.* Blunt cannulas should be used as alternatives to needles wherever possible (i.e., procedures such as oral or intranasal animal inoculations). Needles and syringes should never be used as a substitute for pipettes. When needles and syringes must be used, the following procedures are recommended:

- Use disposable safety-engineered needle-locking syringe units whenever possible.
- When using syringes and needles with biohazardous or potentially infectious agents, work in a biological safety cabinet whenever possible.
- Wear gloves.
- Fill the syringe carefully to minimize air bubbles.
- Expel air, liquid and bubbles from the syringe vertically into a cotton pledget moistened with disinfectant.
- Do not use a syringe to mix infectious fluid forcefully.
- Do not contaminate the needle hub when filling the syringe in order to avoid transfer of infectious material to fingers.
- Wrap the needle and stopper in a cotton pledget moistened with disinfectant when removing a needle from a rubber-stoppered bottle.
- Bending, recapping, clipping or removal of needles from syringes is prohibited. If you must recap or remove a contaminated needle from a syringe, use a mechanical device (e.g. forceps) or the one-handed scoop method. The use of needle-nipping devices is prohibited (needle-nipping devices must be discarded as infectious waste).

- Use a separate pan of disinfectant for reusable syringes and needles. Do not place them in pans containing pipettes or other glassware in order to eliminate sorting later.
- Used disposable needles and syringes must be placed in appropriate sharps disposal containers and discarded as infectious waste.

The Occupational Safety and Health Administration (OSHA) revised the Occupational Exposure to Bloodborne Pathogens Standard (29 CFR Part 1910.1030) in 2001 to include new efforts to help reduce needlestick injuries among healthcare workers and others who handle medical sharps. OSHA now requires the University to involve non-managerial employees in selecting safer medical sharps devices. Evaluative data will be made available in the University of Pennsylvania Exposure Control Plan. If you use sharps and are interested in evaluating safer medical devices, refer to the Safety Engineered Sharps Evaluation Program.

3. Safe and Effective Use of Biological Safety Cabinets

In general:

Make sure your BSC is certified prior to use, when it is installed or after it is moved, and annually thereafter. (For information on cabinet certification contact EHRS by phone (215-898-4453) or email.

- Understand how your cabinet works. The NIH / CDC document, *Primary Containment for Biohazards: Selection, Installation and Use of Biological Safety Cabinets*, provides thorough information. Also consult the manufacturer's operational manual.
- Monitor alarms, pressure gauges or flow indicators for any major fluctuation or changes possibly indicating a problem with the unit. Immediately notify EHRS of cabinets that are not operating properly. DO NOT attempt to adjust the speed control or alarm settings.
- Do not disrupt the protective airflow pattern of the BSC. Make sure lab doors are closed before starting work in the BSC.
- Plan your work and proceed conscientiously.
- Minimize the storage of materials in and around the BSC.
- Hard ducted (Type B2, Total Exhaust) cabinets should be left running at all times. Cabinets that are not vented to the outside may be turned off when not in use, however, be sure to allow the BSC to run for at least 10 minutes before starting work.

Operational directions

- Limit traffic in the area when the cabinet is in use.
- If there is an UV light incorporated within the cabinet, do not leave it on while working in the cabinet or when occupants are in the laboratory.
- Before using, wipe work surface with 70% alcohol. Wipe off each item you need for your procedures and place in cabinet.
- DO NOT place objects over the front air intake grille. Keep all materials at least 4 inches inside the sash. DO NOT place items on top of the unit or block the rear exhaust grille.
- Segregate contaminated and clean items. Work from "clean to dirty."
- Place a pan with disinfectant and/or a sharps container inside the BSC for pipette discards. DO NOT use vertical pipette discard canisters on the floor outside cabinet.
- It is not necessary to flame items. This creates turbulence in airflow and may compromise sterility; heat buildup may damage the filters.
- Move arms slowly when removing or introducing new items into the BSC.
- If you use a piece of equipment that creates air turbulence in the BSC (such as a centrifuge, blender) place equipment in the back 1/3 of the cabinet; stop other work while equipment is operating.
- Protect the building vacuum system from biohazards by placing an in-line HEPA cartridge filter between the vacuum trap system and the source valve in the cabinet.
- Clean up all spills in the cabinet immediately. Allow cabinet to run for 10 minutes before resuming work.
- When work is completed-remove all materials and wipe all interior surfaces with 70% alcohol.
- Remove lab coat and wash hands thoroughly before leaving laboratory.

4. Cryostats

Frozen sections of unfixed human tissue or animal tissue infected with an etiologic agent pose a risk because accidents can occur. Freezing tissue does not necessarily inactivate infectious agents. Freezing propellants under pressure should not be used for frozen sections as they may cause spattering of droplets of infectious material. Gloves should be worn during preparation of frozen sections.

When working with biohazardous material in a cryostat, the following is recommended:

- Consider the contents of the cryostat to be contaminated and decontaminate it frequently with 70% ethanol.
- Consider trimmings and sections of tissue that accumulate in the cryostat to be potentially infectious and remove them during decontamination.
- Defrost and decontaminate the cryostat with a tuberculocidal hospital disinfectant once a week and immediately after tissue known to contain bloodborne pathogens, *M. tuberculosis* or other infectious agents is cut.
- Handle microtome knives with extreme care. Stainless steel mesh gloves should be worn when changing knife blades.
- Consider solutions used for staining potentially infected frozen tissue sections to be contaminated.

5. Centrifuge Equipment

Hazards associated with centrifuging include mechanical failure and the creation of aerosols. To minimize the risk of mechanical failure, centrifuges must be maintained and used according to the manufacturer's instructions. Users should be properly trained and operating instructions that include safety precautions should be prominently posted on the unit.

Aerosols are created by practices such as filling centrifuge tubes, removing plugs or caps from tubes after centrifugation, removing supernatant, and resuspending sedimented pellets. The greatest aerosol hazard is created if a tube breaks during centrifugation. To minimize the generation of aerosols when centrifuging biohazardous material, follow the procedures below:

- Use sealed tubes and safety buckets that seal with O-rings. Before use, inspect tubes, O-rings and buckets for cracks, chips, erosions, bits of broken glass, etc. Do not use aluminum foil to cap centrifuge tubes because it may detach or rupture during centrifugation.
- Fill and open centrifuge tubes, rotors and accessories in a BSC. Avoid overfilling of centrifuge tubes so that closures do not become wet. After tubes are filled and sealed, wipe them down with disinfectant.
- Add disinfectant to the space between the tube and the bucket to disinfect material in the event of breakage during centrifugation.
- Always balance buckets, tubes and rotors properly before centrifugation.

- Do not decant or pour off supernatant. Use a vacuum system with appropriate in-line reservoirs and filters.
- Work in a BSC when re-suspending sedimented material. Use a swirling rotary motion rather than shaking. If shaking is necessary, wait a few minutes to permit the aerosol to settle before opening the tube.

Small low-speed centrifuges may be placed in a BSC during use to contain aerosols.

High-speed centrifuges pose additional hazards. Take precautions to filter the exhaust air from vacuum lines; avoid metal fatigue resulting in disintegration of rotors; and use proper cleaning techniques and centrifuge components. Follow manufacturers' recommendations meticulously to avoid metal fatigue, distortion and corrosion.

Avoid the use of celluloid (cellulose nitrate) tubes with biohazardous materials. Celluloid centrifuge tubes are highly flammable and prone to shrinkage with age. They distort on boiling and can be highly explosive in an autoclave. If celluloid tubes must be used, an appropriate chemical disinfectant must be used to decontaminate them.

6. Personal Protective Equipment

OSHA standard 29 CFR 1910.132 requires workplace assessment for potential hazards and mandates that employers provide appropriate PPE for employees. PPE is used to protect personnel from contact with hazardous materials and infectious agents. Appropriate clothing may also protect the experiment from contamination. PPE must be provided without cost to personnel. Supervisors are responsible to perform the assessments and to select and train employees in the use of routine items such as lab coats, protective gloves, safety glasses, face shields, etc. For assistance in selection of PPE contact EHRS. The following PPE is recommended for regular use:

Face Protection

Goggles or safety glasses with solid side shields in combination with masks, or chin length face shields or other splatter guards are required for anticipated splashes, sprays or splatters of infectious or other hazardous materials to the face. Information on safety eyewear and the availability of low cost prescription safety eyewear is available at the EHRS website.

Laboratory Clothing

This category includes: laboratory coats, smocks, scrub suits, and gowns. Long sleeved garments should be used to minimize the contamination of skin or street clothes and to reduce shedding of microorganisms from the arms. In a circumstance where it is anticipated that splashes may occur, the garment must be resistant to liquid penetration to protect clothing from contamination. If the garment is not disposable, it must be capable of withstanding sterilization, in the event it becomes contaminated. Additional criteria for selecting clothing are: comfort, appearance, closure types and location, antistatic properties and durability. Protective clothing must be removed and left in the laboratory before leaving for non-laboratory areas. If required, disposables should be provided for visitors, maintenance and service workers. All protective clothing should be either discarded in the laboratory or laundered by the facility. Personnel must not launder laboratory clothing at home.

Gloves

Gloves must be selected based on the hazards involved and the activity to be conducted. Gloves must be worn when working with biohazards, toxics and other physically hazardous agents. Temperature resistant gloves must be worn when handling hot material or dry ice. Delicate work requiring a high degree of precision dictates the use of thin walled gloves. Protection from contact with toxic or corrosive chemicals may also be required. In addition, for some workers, exposures to latex may result in allergic reactions. Reports of such reactions have increased in recent years, prompting EHRS to recommend the use of nitrile gloves over latex gloves. For assistance in glove selection, contact EHRS.

When working with hazardous materials, the glove should overlap the lower sleeve and the cuff of the laboratory garment. A long sleeved glove or disposable arm-shield may be worn for further protection of the garment.

In some instances double gloving may be appropriate. If a spill occurs, hands will be protected after the contaminated outer gloves are removed. Gloves must be disposed of when torn or contaminated, removed when work with infectious materials is completed and not worn outside the laboratory. Disposable gloves must not be washed or reused. Gloves must be removed correctly in order to avoid contamination. Follow the procedure below to remove gloves safely*:



Pull one glove near your wrist towards your fingertips until the glove folds over.



Carefully grab the fold and pull towards your fingertips. As you pull you are turning the inside of the glove outwards.



Pull the fold until the glove is almost off. To avoid contamination of your environment, continue to hold the removed glove. Completely remove your hand from the glove.



Slide a finger from your glove-free hand under the remaining glove. Continue to slide your finger towards your fingertips until almost half of your finger is under the glove.



Turn you finger 180 degrees and pull the glove outwards and towards your fingertips. As you do this, the first glove will be encased in the second glove. The inside of the second glove will also be turned outwards.



Grab the gloves firmly, by the uncontaminated surface (the side that was originally touching your hand). Release your grasp of the first glove you removed. Pull your second hand free from its glove. Dispose of the gloves properly.

Respirators

In certain instances additional PPE may be required. Respirator selection is based on the hazard and the protection factor required. If your work requires the use of a respirator, you must participate in the University's respiratory protection program. Personnel who require respiratory protection must be medically evaluated by Occupational Medicine prior to respirator use. After evaluation, EHRS must assist the user in respirator selection and usage training. Contact EHRS to initiate the process.

7. Aerosol Producing Devices

The use of devices such as *ultrasonic disrupters, grinders and homogenizers* to disrupt biohazardous materials results in considerable aerosol production and should be performed in a BSC whenever possible. Special care and barrier protection (splash shields, goggles, bench napkins, gloves, etc.) are important not only during the agitation/disruption process but also when handling the finished product. Allow your vessel to sit for a short time to allow your product to settle before opening. Review the operations manual for the device you are using, paying special attention to those areas of the device that are susceptible to contamination by your product and decontaminate appropriately after use, especially when working with potentially infectious materials.

Safety blenders are designed to prevent leakage from the bottom of the blender jar, provide a cooling jacket to avoid biological inactivation and to withstand sterilization by autoclaving. If blender rotors are not leak proof, test them with sterile saline or dye solution prior to use with biohazardous material. The use of glass blender jars is not recommended because of the breakage potential. If they must be used, cover the glass jar with a polypropylene jar to prevent spraying of glass and contents in the event it breaks. Use safety blenders in a BSC to prevent the accidental release of aerosol during the blending process. During use, place a towel moistened with disinfectant over the top of the blender. Before opening the blender jar, allow the unit to rest for at least one minute to allow the aerosol to settle. Decontaminate the device promptly after use.

Lyophilizers may be used to freeze-dry biohazardous material. Depending on each lyophilizer design, infectious aerosol production may occur when biohazardous material is loaded or removed from the lyophilizer unit. If possible, load sample material in a BSC. Be sure the vacuum pump exhaust is HEPA-filtered to remove any hazardous agents or, alternatively, vent the pump into a BSC. After lyophilization is completed, disinfect all surfaces of the unit that have been exposed to the agent. If the lyophilizer is equipped with a removable chamber, close it off and move it to a BSC for unloading and decontamination. Handle cultures as infrequently as possible and use vapor traps wherever possible.

Open all glass *ampoules* containing liquid or lyophilized culture material in a BSC to contain the aerosol produced. Gloves must be worn. To open, nick the neck of the ampoule with a file, wrap it in disinfectant soaked towel, hold the ampoule upright and snap it open at the nick. Reconstitute the contents of the ampoule by slowly adding liquid to avoid aerosolization of the dried material. Mix the contents without bubbling and withdraw it into a fresh container. Discard the towel and ampoule top and bottom as infectious waste.

Glass ampoules used to store biohazardous material in liquid nitrogen have exploded causing eye injuries. The use of polypropylene tubes eliminates this hazard. These tubes are available dust-free or pre-sterilized and are fitted with polyethylene caps with silicone washers. Heat sealable polypropylene tubes are also available.

8. Loop Sterilizers and Bunsen Burners

Sterilization of inoculating loops or needles in an open flame generates small-particle aerosols that may contain viable microorganisms. The use of a shielded electric incinerator minimizes aerosol production during loop sterilization. Alternatively, disposable plastic loops and needles may be used for culture work where electric incinerators or gas flames are not available. The loops are semi-quantitative and can be used for counting bacteria.

The use of gas burners in BSCs is not recommended. These burners can produce turbulence that disturbs the protective airflow patterns of the cabinet. In many biosafety cabinets, a portion of the total air volume is recirculated in the work area allowing flammable vapors or gases to accumulate thereby creating a fire hazard. Additionally, the heat produced by the continuous flame may damage the HEPA filter.

If a gas burner must be used, select a touch-plate burner with a pilot light. In addition, appropriate hard piping from the house gas line must be used and an easily accessible emergency shut-off valve (specifically identified as such) must be placed on the outside of the biosafety cabinet.

9. Laundry

All personal protective clothing must be cleaned, laundered and disposed of by the employer at no cost to employees. Apparel contaminated with blood or other potentially infectious materials should be handled as little as possible and decontaminated, preferably by autoclaving, before being sent to the laundry for cleaning. Employees who handle contaminated laundry must wear appropriate PPE.

10. Housekeeping

Good housekeeping in laboratories is essential to reduce risks and protect the integrity of biological experiments. Routine housekeeping must be relied upon to provide work areas free of significant sources of contamination. Housekeeping procedures should be based on the highest degree of risk to which personnel and experimental integrity may be subjected.

Laboratory personnel are responsible to clean laboratory benches, equipment and areas that require specialized technical knowledge. Laboratory staff is responsible to:

- Secure biohazardous materials at the conclusion of work.
- Keep the laboratory neat and free of clutter - surfaces should be clean and free of infrequently used chemicals, biologicals, glassware and equipment. Access to sinks, eyewashes, emergency showers and fire extinguishers must not be blocked.
- Decontaminate and discard infectious waste – do not allow it to accumulate in the laboratory.
- Dispose of old and unused chemicals promptly and properly. To have your waste chemicals removed, complete an EHRS Chemical Waste Pickup form.
- Provide a workplace that is free of physical hazards - aisles and corridors should be free of tripping hazards. Attention should be paid to electrical safety, especially as it relates to the use of extension cords, proper grounding of equipment, avoidance of overloaded electrical circuits and avoidance of the creation of electrical hazards in wet areas.
- Remove unnecessary items on floors, under benches or in corners.
- Properly secure all compressed gas cylinders.
- Never use fume hoods or biosafety cabinets for storage.

Practical custodial concerns include:

- Dry sweeping and dusting that may lead to the formation of aerosols is not permitted.
- The use of a wet or dry industrial type vacuum cleaner is prohibited to protect personnel as well as the integrity of the experiment. They are potent aerosol generators and, unless equipped with high efficiency particulate air (HEPA) filters, must not be used in the biological research laboratory. Wet and dry units with HEPA filters on the exhaust are available from a number of manufacturers.

11. Biohazard Spill Cleanup Procedures

The following procedures are provided as a guideline to biohazardous spill cleanup.

a. Biosafety Level 2 Spill Protocol

NOTE: If spill also involves radioactive materials, contact EHRS at 215-898-7187.

Instruct injured personnel to go to Occupational Medicine, (first floor, Silverstein), HUP, immediately. Ask a co-worker to call ahead to alert Occupational Medicine (215-662-2354). If transportation assistance is required, call Penn Police at 511 or 215-898-7297. After hours, injured personnel should go directly to HUP Emergency Room.

Small spills:

Wipe up spill with a disinfectant-soaked paper towel & clean the surface with a suitable disinfectant.

Larger spills:

Within a Biological Safety Cabinet (BSC)

- BSC must run during cleanup to contain aerosols & HEPA-filter exhaust air.
- Don appropriate personal protective gear before initiating cleanup.
- Initiate clean up as soon as possible using a germicidal disinfectant (phenolic or iodophor). Alcohol is not recommended. Large quantities may create the risk of fire.
- If the spill is contained on a bench diaper, remove the contaminated bench diaper & discard as infectious waste.
- If the spill is on the work area surface, cover spilled material with disinfectant-soaked towels. Allow 20 minutes contact time then remove the contaminated towels & discard as infectious waste.
- Wipe down the interior of the cabinet & any splatter on items within the cabinet with a disinfectant-soaked towel.

- Wipe down non-autoclavable materials with disinfectant. Allow 20 minutes of contact time with disinfectant before any items are removed from cabinet.
- Place items designated as contaminated used sharps in an appropriate infectious waste sharps container using tongs/forceps. Place other contaminated disposable materials used in the cleanup process in an autoclave bag. Process as infectious waste.
- Place contaminated re-usable items in biohazard bags, autoclavable pans with lids or wrap them in newspaper. Sterilize, preferably by autoclaving, then clean for re-use.
- If the cabinet has a catch basin beneath the work surface & the spill resulted in liquids flowing into this area, more extensive decontamination is required.
 1. Ensure the drain valve under the cabinet is closed.
 2. Pour disinfectant onto the work surface & through the front and rear grilles into the drain pan. Allow 20-30 minutes contact time.
 3. Absorb spilled fluid-disinfectant from work surface with paper towels & discard in biohazard bag.
 4. Prepare to empty drain pan. Place disinfectant solution in a collection vessel. Attach flexible tubing to the drain valve. The tube should be of sufficient length to allow the open end to be submerged in the collection vessel to minimize aerosol generation.
 5. Open the drain valve & empty the drain pan into the collection vessel containing disinfectant. Flush the drain pan with water & remove the flexible tubing. Manage contaminated materials as if they are infectious.
 6. Remove protective clothing used during cleanup & place in a biohazard bag for autoclaving. Wash hands when gloves are removed.
 7. Notify Principal Investigator or supervisor and EHRS (215-898-4453). Consult with EHRS to determine whether formaldehyde decontamination of the cabinet and filters is necessary, especially if a

high-risk agent or a major spill of a moderate-risk agent occurred.

8. Run BSC at least 10 minutes after cleanup, before resuming activity in the cabinet.

Outside the Cabinet, Inside the Laboratory

- If a spill occurs in a Biosafety Level 2 facility, outside the BSC, notify other individuals in the laboratory to evacuate.
- Exit the laboratory to the hallway, closing the door behind you.
- Remove any contaminated clothing (turn contaminated portion inward) & place it in an autoclave bag.
- Wash all exposed skin.
- Place signs on door(s) to the laboratory warning individuals who may want to enter that a spill occurred & access is denied.
- Allow aerosols to settle for 30 minutes before re-entering the laboratory.
- Assemble supplies (disinfectant, sharps containers, towels, tongs, autoclave bags, etc.) before entering the laboratory.
- Don appropriate personal protective equipment (i.e. disposable gown, protective eyewear, gloves, shoe coverings & respiratory protection [if needed]).
- Clean up spill with a suitable disinfectant as follows:
 1. Surround spill area with disinfectant or diking material that is soaked in disinfectant.
 2. Place paper towels soaked in a disinfectant over the entire spill area.
 3. Allow 20-minute contact time with the disinfectant to ensure adequate germicidal action.
 4. Wipe down non-autoclavable materials with germicidal disinfectant.

5. Place items designated as contaminated used sharps in an appropriate infectious waste sharps container. Place other disposable materials used in the cleanup process in an autoclave bag. Process as infectious waste.
 6. Place contaminated re-usable items in biohazard bags, autoclavable pans with lids or wrap them in newspaper. Sterilize, preferably by autoclaving, then clean for re-use. Remove protective clothing used during cleanup then place in a biohazard bag for autoclaving.
- Wash hands when gloves are removed.
 - Notify Principal Investigator or supervisor & EHRS (215-898-4453)

Inside a Centrifuge

The potential for multiple infections from a single centrifuge accident is great. Aerosols are created when fluid escapes from the rotor or cup while the centrifuge is operating at high speed. All opening of centrifuges must be performed slowly.

Unsealed buckets:

- If a centrifuge tube breaks while the centrifuge is running, turn off motor. Allow the machine to be at rest for 30 minutes before opening. If breakage is discovered after the machine has stopped, re-close the lid immediately & allow the unit to be at rest for 30 minutes.
- Unplug centrifuge before initiating clean up.
- Don strong, thick rubber gloves & other PPE before proceeding with clean up.
- Flood centrifuge bowl with a germicidal disinfectant. Place paper towels soaked in a disinfectant over the entire spill area. Allow 20 minutes contact time.

- Use mechanical means (such as forceps) to remove broken tubes & glass fragments. Place them in a sharps container for autoclaving & disposal as infectious waste.
- Remove buckets, trunnions & rotor then place in disinfectant for 24 hours or autoclave.
- Unbroken, capped tubes may be placed in disinfectant & recovered after 20 minutes contact time or autoclaved.
- Use mechanical means to remove remaining disinfectant soaked materials from centrifuge bowl & discard as infectious waste.
- Place paper towels soaked in a disinfectant in the centrifuge bowl & allow it to soak overnight, wipe down again with disinfectant, wash with water & dry. Discard disinfectant soaked materials as infectious waste.
- Remove protective clothing used during cleanup & place in a biohazard bag for autoclaving. Wash hands whenever gloves are removed.

Sealed buckets (safety cups):

- If breakage is suspected, remove the sealed bucket to a biological safety cabinet before opening.
- If breakage occurred, replace the cap on the safety cup loosely and autoclave.
- Notify Principal Investigator or supervisor & EHRS (215-898-4453).

Outside the Laboratory; during Transport (on Penn's Campus)

The major emphasis should be on preventing spills during transport. All transport of infectious materials must be in a rigid, securely sealed, watertight primary container, which is contained within a second rigid, leak proof sealed container. Sufficient absorbent should be added to the second container to take up contents in case of leakage from the primary container. The outer container must be labeled with the universal biohazard symbol.

If a spill occurs during transport, don gloves and initiate cleanup immediately as follows:

- Surround spill area with disinfectant or diking material that is soaked in disinfectant.
- Place paper towels soaked in a disinfectant over the entire spill area.
- Allow a minimum 20 minutes contact time with the disinfectant to ensure adequate germicidal action.
- Place contaminated used sharps in an appropriate infectious waste sharps container.
- Place other materials used in the cleanup process (including contaminated gloves) in an autoclave bag and process as infectious waste.
- Repeat decontamination of spill area after contaminated materials are removed.
- Wash hands as soon as possible.

Contact EHRS (215-898-4453) if assistance is needed.

b. Biosafety Level 3 Spill Protocol

NOTE: All laboratory personnel (faculty, staff, students) working with a Risk Group 3 agent in a Biosafety Level 3 facility must be trained in the use of respiratory equipment by the EHRS prior to beginning work.

If spill involves radioactive materials, contact EHRS immediately at 215-898-7187.

Instruct injured personnel to go to Occupational Medicine, (first floor, Silverstein), HUP, immediately. Ask a co-worker to call ahead to alert Occupational Medicine (215-662-2354). If transportation assistance is required, call Penn Police at 511 or 215-898-7297. After hours, injured personnel should go directly to HUP Emergency Room.

Within a Biological Safety Cabinet (BSC)

- BSC must run during cleanup to contain aerosols & HEPA-filter exhaust air.
- Don appropriate personal protective gear before initiating cleanup (disposable back-closing gown, double gloves).

- Initiate clean up as soon as possible using a germicidal disinfectant (phenolic or iodophor). Alcohol is not recommended. Large quantities may create the risk of fire.
- If the spill is contained on a bench diaper, remove the contaminated bench diaper & discard as infectious waste.
- If the spill is on the work area surface, cover spilled material with disinfectant-soaked towels. Allow 20 minutes contact time then remove the contaminated towels & discard as infectious waste.
- Wipe down the interior of the cabinet & any splatter on items within the cabinet with a disinfectant-soaked towel.
- Wipe down non-autoclavable materials with disinfectant. Allow 20 minutes of contact time with disinfectant before any items are removed from cabinet.
- Place items designated as contaminated used sharps in an appropriate infectious waste sharps container *using tongs/forceps*. Place other contaminated disposable materials used in the cleanup process in an autoclave bag. Process as infectious waste.
- Place contaminated re-usable items in biohazard bags, autoclavable pans with lids or wrap them in newspaper. Sterilize, preferably by autoclaving, then clean for re-use.
- If the cabinet has a catch basin beneath the work surface & the spill resulted in liquids flowing into this area, more extensive decontamination is required.
 1. Ensure the drain valve under the cabinet is closed.
 2. Pour disinfectant onto the work surface & through the front and rear grilles into the drain pan. Allow 20-30 minutes contact time.
 3. Absorb spilled fluid-disinfectant from work surface with paper towels & discard in biohazard bag.
 4. Prepare to empty drain pan. Place disinfectant solution in a collection vessel. Attach flexible tubing to the drain valve. The tube should be of sufficient length to allow the open end to be submerged in the collection vessel to minimize aerosol generation.

5. Open the drain valve & empty the drain pan into the collection vessel containing disinfectant. Flush the drain pan with water & remove the flexible tubing. Manage contaminated materials as if they are infectious.
 - Remove protective clothing used during cleanup & place in a biohazard bag for autoclaving. Wash hands when gloves are removed.
 - Notify Principal Investigator or supervisor and EHRS (215-898-4453). Consult with EHRS to determine whether formaldehyde decontamination of the cabinet and filters is necessary, especially if a high-risk agent or a major spill of a moderate-risk agent occurred.
 - Run BSC at least 10 minutes after cleanup, before resuming activity in the cabinet.

Outside the Cabinet, Inside the Laboratory

- Notify other individuals in the laboratory to evacuate the laboratory immediately.
- Hold your breath and exit the laboratory to the anteroom.
- Remove contaminated clothing (turn contaminated portion inward; place into autoclave bag). Wash hands after gloves are removed.
- Wash all exposed skin with germicidal soap. If eyes were splashed, flush at eyewash station for 15 minutes then report to Occupational Medicine.
- Notify Principal Investigator or supervisor and EHRS (215-898-4453). EHRS will consult with the Principal Investigator to determine the appropriate method of decontamination and spill cleanup (personnel spill response or formaldehyde decontamination of the entire facility).
- Place a sign on the door to the BL3 lab to warn individuals of the spill and advise them keep out of the lab.

If personnel spill response is required, do the following:

- Allow aerosols to settle for a minimum of 30 minutes before re-entering the laboratory.
- Assemble supplies (disinfectant, sharps containers, towels, tongs, autoclave bags and protective gear [disposable Tyvek suit/back-closing gown, protective eyewear, gloves, shoe coverings, respirator], etc.) before initiating spill cleanup.
- Don appropriate personal protective equipment (PPE). Double gloving is recommended.
- Clean up spill with a suitable disinfectant as follows:
 1. Surround spill area with disinfectant or diking material that is soaked in disinfectant.
 2. Place paper towels soaked in a disinfectant over the entire spill area.
 3. Allow a minimum 20 minutes contact time with the disinfectant to ensure adequate germicidal action.
 4. Wipe down non-autoclavable materials with germicidal disinfectant, allowing 20-minute contact time.
 5. Place items designated as contaminated used sharps in an appropriate infectious waste sharps container *using tongs/forceps*. Place other contaminated disposable materials used in the cleanup process in an autoclave bag. Process as infectious waste.
 6. Place contaminated autoclavable re-usable items in biohazard bags, autoclavable pans with lids or wrap them in newspaper. Sterilize, preferably by autoclaving, then clean for re-use.
 7. Repeat decontamination of spill area (floor and work surfaces) after contaminated materials are removed.
- Remove outer gloves before exiting laboratory to the anteroom.
- Remove protective clothing used during cleanup in the following order: shoe coverings, gown/suit, respirator, and

gloves last. If reusable, wipe down respirator with disinfectant. Place disposable PPE in a biohazard bag for autoclaving.

- Wash hands with germicidal soap after gloves are removed; shower recommended.

Inside a Centrifuge

The potential for multiple infections from a single centrifuge accident is great. Aerosols are created when fluid escapes from the rotor or cup while the centrifuge is operating at high speed. All opening of centrifuges must be performed slowly.

- If a centrifuge tube breaks while the centrifuge is running, turn off the motor, notify others in the lab, hold your breath, and evacuate. *Allow the centrifuge to be at rest for 30 minutes before attempting to open.*
- Notify Principal Investigator or supervisor and EHRS (215-898-4453). EHRS will consult with the Principal Investigator to determine the most appropriate method of decontamination and spill cleanup.
- Place a sign on the door to the BL3 lab, to warn individuals of the spill and to keep out of the lab.

If personnel spill response is required, do the following:

- Assemble supplies (disinfectant, sharps containers, towels, tongs, autoclave bags and protective gear [disposable Tyvek suit/back-closing gown, protective eyewear, gloves, shoe coverings, respirator], etc.) before initiating spill cleanup.
- Don appropriate personal protective equipment (PPE). Double gloving is recommended. Re-enter BL3 lab.
- Unplug centrifuge and slowly open centrifuge.
- If safety cup(s) is intact, remove unit to biological safety cabinet for further decontamination.

- If integrity of safety cup(s) is breached, decontaminate all exposed surfaces before removing cup(s) to biological safety cabinet for further decontamination.

Outside the Laboratory; during Transport (on Penn's Campus)

The major emphasis should be on preventing spills during transport. Please note that transportation of a large number of cultures at the same time is discouraged. If a cart is used to transport the material, it must have side rails. All transport of infectious materials must be in a rigid, securely sealed, watertight primary container, which is contained within a second rigid, sealed, leak-proof container. Sufficient absorbent should be added to the second container to take up contents in case of leakage. The outer container must be labeled with the universal biohazard symbol. The container should be placed on the bottom shelf of the cart.

If a spill occurs during transport, don gloves and initiate cleanup immediately as follows:

- Place absorbent towels, preferably soaked in a disinfectant, on the spilled material.
- Contact EHRS (215-898-4453). Remain nearby until EHRS arrives to assist in the spill cleanup.

D. Decontamination

Decontamination is a term used to describe a process or treatment that renders a medical device, instrument, or environmental surface safe to handle. A decontamination procedure can range from sterilization to simple cleaning with soap and water. Sterilization, disinfection and antisepsis are all forms of decontamination.

Sterilization is the use of a physical or chemical procedure to destroy all microbial life, including highly resistant bacterial endospores.

Disinfection eliminates virtually all pathogenic non-spore-forming microorganisms but not necessarily all microbial forms on inanimate objects (work surfaces, equipment, etc.). Effectiveness is influenced by the kinds and numbers of organisms, the amount of organic matter, the object to be disinfected and chemical exposure time, temperature and concentration.

Antisepsis is the application of a liquid antimicrobial chemical to skin or living tissue to inhibit or destroy microorganisms. It includes swabbing an injection site on a person or animal and hand washing with germicidal solutions. Although some chemicals may be utilized as either a disinfectant or an antiseptic, adequacy for one application does not

guarantee adequacy for the other. Manufacturers' recommendations for appropriate use of germicides should always be followed.

Methods

There are four main categories of physical and chemical means of decontamination. They are heat, liquid disinfection, vapors and gases and radiation. Each category is discussed briefly below.

Heat

Wet heat is the most dependable method of sterilization. Autoclaving (saturated steam under pressure of approximately 15 psi to achieve a chamber temperature of at least 250° F for a prescribed time) rapidly achieves destruction of microorganisms, decontaminates infectious waste and sterilizes laboratory glassware, media, and reagents. For efficient heat transfer, steam must flush the air out of the autoclave chamber. Before using the autoclave, check the drain screen at the bottom of the chamber and clean it, if blocked. If the sieve is blocked with debris, a layer of air may form at the bottom of the autoclave, preventing efficient operation. Prevention of entrapment of air is critical to achieving sterility. Material to be sterilized must come in contact with steam and heat.

Chemical indicators, e.g. autoclave tape, must be used with each load placed in the autoclave. The use of autoclave tape alone is not an adequate monitor of efficacy. Autoclave sterility monitoring should be conducted on a regular basis (at least monthly) using appropriate biological indicators (*B. stearothermophilus* spore strips) placed at locations throughout the autoclave. The spores, which can survive 250° F for 5 minutes but are killed at 250° F in 13 minutes, are more resistant to heat than most, thereby providing an adequate safety margin when validating decontamination procedures. Each type of container employed should be spore tested because efficacy varies with the load, fluid volume, etc.

Warranties and preventive maintenance plans for all autoclaves are strongly recommended by EHRS.

Each individual working with biohazardous material is responsible for its proper disposition. Decontaminate all infectious materials and all contaminated equipment or labware before washing, storage or discard as infectious waste. Autoclaving is the preferred method. Never leave an autoclave in operation unattended (do not start a cycle prior to leaving for the evening).

Recommended procedures for autoclaving are:

- All personnel using autoclaves must be adequately trained by their PI or lab manager. Never allow untrained personnel to operate an autoclave.

- Be sure all containment vessels can withstand the temperature and pressure of the autoclave. Be sure to use polypropylene / polyethylene autoclave bags.
- Review the operator's manual for instructions prior to operating the unit. Different makes and models have unique characteristics.
- Never exceed the maximum operating temperature and pressure of the autoclave.
- Wear the appropriate personal protective equipment (safety glasses, lab coat and heat-resistant gloves) when loading and unloading an autoclave.
- Select the appropriate cycle: liquid cycle (slow exhaust) for fluids to prevent boiling over, dry cycle (fast exhaust) for glassware, fast and dry cycle for wrapped items.
- Never place autoclave bags directly on the autoclave chamber floor. Place autoclavable bags containing waste in a secondary containment vessel to retain any leakage that might occur. The secondary containment vessel must be constructed of material that will not melt or distort during the autoclave process. (Polypropylene is a plastic capable of withstanding autoclaving but is resistant to heat transfer. Materials contained in a polypropylene pan will take longer to autoclave than the same material in a stainless steel pan.)
- Never place sealed bags or containers in the autoclave. Polypropylene bags are impermeable to steam and should not be twisted and taped shut. Secure the top of containers and bags loosely to allow steam penetration.
- Position autoclave bags with the neck of the bag taped loosely and leave space between items in the autoclave bag to allow steam penetration.
- Fill liquid containers only half full, loosen caps or use vented closures.
- For materials with a high insulating capacity (animal bedding, saturated absorbent, etc.) increase the time needed for the load to reach sterilizing temperatures.
- Never autoclave items containing solvents, volatile or corrosive chemicals.

- Always make sure that the pressure of the autoclave chamber is at zero before opening the door. Stand behind the autoclave door and slowly open it to allow the steam to gradually escape from the autoclave chamber after cycle completion.
- Allow liquid materials inside the autoclave to cool down for 15-20 minutes prior to their removal.
- Dispose of all autoclaved waste through the infectious waste stream.

Dry heat is less efficient than wet heat and requires longer times and/or higher temperatures to achieve sterilization. It is suitable for the destruction of viable organisms on impermeable non-organic surfaces such as glass, but it is not reliable in the presence of shallow layers of organic or inorganic materials which may act as insulation. Sterilization of glassware by dry heat can usually be accomplished at 160-170° C for periods of 2-4 hours. Dry heat sterilizers should be monitored on a regular basis using appropriate biological indicators [*B. subtilis (globigii)* spore strips].

Incineration is another effective means of decontamination by heat. As a disposal method incineration has the advantage of reducing the volume of the material prior to its final disposal. However, local and federal environmental regulations contain stringent requirements and permits to operate incinerators are increasingly more difficult to obtain.

Liquid Disinfection

The most practical use of liquid disinfectants is for surface decontamination and, when used in sufficient concentration, as a decontaminant for liquid wastes prior to final disposal in the sanitary sewer. If liquid disinfectants are used, they must have been shown to be effective against the organism(s) present.

Liquid disinfectants are available under a wide variety of trade names. In general, these can be classified as: halogens, acids, alkalis, heavy metal salts, quaternary ammonium compounds, phenolic compounds, aldehydes, ketones, alcohols and amines. The more active a compound is, the more likely it is to have undesirable characteristics such as corrosivity. No liquid disinfectant is equally useful or effective under all conditions and for all viable agents.

Properties of common disinfectants may be found in 'Table 3: Properties of Common Decontamination Methods'

Vapors and Gases

A variety of vapors and gases possess decontamination properties. Vapors and gases are primarily used to decontaminate biological safety cabinets and associated systems, bulky or stationary equipment not suited to liquid disinfectants, instruments or optics which might be damaged by other decontamination methods, and rooms, buildings and associated air-handling systems. Agents included in this category are glutaraldehyde and formaldehyde vapor, ethylene oxide gas, peracetic acid and hydrogen peroxide vapor.

When used in closed systems and under controlled conditions of temperature and humidity, excellent disinfection can be obtained. Great care must be taken during use because of the hazardous nature of many of these compounds. Contact EHRS for monitoring requirements if these compounds are to be used.

Radiation

Although ionizing radiation will destroy microorganisms, it is not a practical tool for laboratory use. Non-ionizing radiation in the form of ultraviolet radiation (UV) is used for inactivating viruses, bacteria and fungi. It will destroy airborne microorganisms and inactivate microorganisms on exposed surfaces or in the presence of products of unstable composition that cannot be treated by conventional means.

Because of the low penetrating power of UV, microorganisms inside dust or soil particles will be protected from its action, limiting its usefulness. UV is used in air locks, animal holding areas, ventilated cabinets and laboratory rooms to reduce levels of airborne microorganisms and maintain good air hygiene. Because UV can cause burns to the eyes and skin of people exposed for even a short period of time, proper shielding should be maintained when it is in use. UV lamps that are used for space decontamination should be interlocked with the general room or cabinet illumination, so that turning on the lights extinguishes the UV.

UV lamps are not recommended for decontamination unless they are properly maintained. Because UV lamp intensity or destructive power decreases with time, it should be checked with a UV meter yearly. Frequent cleaning every few weeks is necessary to prevent accumulation of dust and dirt on the lamp that also reduces its effectiveness drastically. If UV must be used, it should be used when areas are not occupied. For more information, see the EHRS fact sheet on UV.

E. Infectious Waste Management

Infectious waste, as defined below, is regulated in Pennsylvania by the Department of Environmental Protection. It is the responsibility of generators to properly sort and dispose of all infectious waste following the policies and procedures established by EHRS. Infectious waste management varies across Schools within the University. For specific information on infectious waste disposal procedures and pickup locations in your facility, call your Building Administrator, Facilities Management Office or EHRS. Any off-site treatment of infectious waste must be coordinated through EHRS (215-898-4453).

1. Categories of infectious waste:

a. Cultures and stocks of infectious agents and associated biologicals, including the following:

cultures from medical and pathological laboratories;

cultures and stocks of infectious agents from research and industrial laboratories;

wastes from the production of biologicals;

discarded live and attenuated vaccines except for residue in emptied containers;

culture dishes, assemblies and devices used to conduct diagnostic tests or to transfer, inoculate and mix cultures.

b. Pathological wastes: : human pathological wastes, including: tissues, organs and body parts and body fluids that are removed during surgery, autopsy, other medical procedures, or laboratory procedures. Hair, nails and extracted teeth are excluded.

c. Human blood, blood products and body fluid waste:

- liquid waste human blood;
- human blood products;
- items saturated or dripping with human blood;
- items that are caked with dried human blood, including serum, plasma, and other blood components, which were used or intended for use in patient care, specimen testing or the development of pharmaceuticals;
- intravenous bags that have been used for blood transfusions;
- items, including dialysate, that have been in contact with the blood of patients undergoing hemodialysis at hospitals or independent treatment centers;
- items contaminated by body fluids from persons during surgery, autopsy, other medical or laboratory procedures;
- specimens of blood products or body fluids, and their containers.

d. Animal wastes: contaminated animal carcasses, body parts, blood, blood products, secretions, excretions and bedding of animals that were known to have been exposed to zoonotic infectious agents or non-zoonotic human pathogens during research (including research in veterinary schools and hospitals), production of biologicals or testing of pharmaceuticals.

e. Isolation wastes: biological wastes and waste contaminated with blood, excretion, exudates or secretions from:

- humans who are isolated to protect others from highly virulent diseases,
- isolated animals known or suspected to be infected with highly virulent diseases.

f. Used sharps: sharps, including hypodermic needles, syringes, (with or without the attached needle), pasteur pipettes, scalpel blades, blood vials, needles with attached tubing, culture dishes, suture needles, slides, cover slips and other broken or unbroken glass or plasticware that have been in contact with infectious agents or that have been used in animal or human patient care or treatment, at medical, research, or industrial laboratories.

2. Handling

All infectious waste from University laboratories must be autoclaved by the generator prior to disposal in appropriate infectious waste containers. Treatment of infectious waste, other than by autoclaving, must be reviewed by EHRS.

The primary responsibility for identifying and disposing of infectious material rests with principal investigators or laboratory supervisors. This responsibility cannot be shifted to inexperienced or untrained personnel.

Potentially infectious and biohazardous waste must be separated from general waste at the point of generation (i.e., the point at which the material becomes a waste) by the generator into the following three classes as follows:

- Used Sharps
- Fluids (volumes greater than 20 cc)
- Other

Used sharps must be segregated into sharps containers that are non-breakable, leak proof, impervious to moisture, rigid, tightly lidded, puncture resistant, red in color and marked with the universal biohazard symbol. Sharps containers may be used until 2/3-3/4 full, at which time they must be decontaminated, preferably by autoclaving, and disposed of as infectious waste. Greater details on sharps management are provided at the EHRS website.

Fluids in volumes greater than 20 cc that are discarded as infectious waste must be segregated in containers that are leak proof, impervious to moisture, break-resistant, tightly lidded or stoppered, red in color and marked with the universal biohazard symbol. To minimize the burden of three waste categories, fluids in volumes greater than 20 cc, may be decontaminated (by autoclaving or exposure to an appropriate disinfectant), then flushed into the sanitary sewer system. The pouring of these wastes must be accompanied by large amounts of water. The empty fluid container may be autoclaved, then discarded with other infectious waste if it is disposable or autoclaved and washed if reusable.

Other infectious waste must be discarded directly into containers or plastic (polypropylene) autoclave bags that are clearly identifiable and distinguishable from general waste. Containers must be marked with the universal biohazard

symbol. Autoclave bags must be distinctly colored red or orange, and marked with the universal biohazard symbol. These bags must not be used for any other materials or purpose.

Infectious waste that is decontaminated on the same floor or within the same building must be carried in a closed, durable, non-breakable container labeled with the biohazard symbol. Materials transported to other facilities must be packaged in a closed durable, non-breakable container labeled with the biohazard symbol.

3. Mixed Waste

Provisions must be made for potentially infectious waste with multiple hazards, e.g., radioactive material contaminated wastes, or wastes substantially contaminated with toxic/carcinogenic compounds. Contact EHRS (215-898-4453) regarding the disposal of these wastes.

4. Storage

Infectious waste must not be allowed to accumulate. Contaminated material should be inactivated and disposed of daily or on a regular basis as required. If the storage of contaminated material is necessary, it must be done in a rigid container away from general traffic and labeled appropriately.

Infectious waste, excluding used sharps, may be stored at room temperature until the storage container is full, but no longer than 30 days from the date of generation. It may be refrigerated for up to 30 days and frozen for up to 90 days from the date of generation. Infectious waste must be dated when refrigerated or frozen for storage. Storage of infectious waste in a freezer must be approved by EHRS.

If infectious waste becomes putrescent during storage it must be moved offsite within 24 hours for processing and disposal.

5. Monitoring Treatment of Infectious Waste

Autoclaving of infectious waste must be monitored to assure the efficacy of the treatment method. A log noting the date, test conditions and the results of each test of the autoclave must be kept.

6. Animals

Disposal of research animals and animal parts that are considered to be infectious waste is coordinated through University Laboratory Animal Resources (ULAR). Disposal of animal carcasses in the general trash is prohibited.

F. Transport of Biological Materials

1. Intramural Transport

When transporting biohazardous materials on campus, take precautions to communicate the hazard to those around you as well as to prevent an accidental spill. Transport all biohazardous materials (tissues, blood samples, contaminated supplies, etc.) in a rigid, securely sealed, watertight primary container, contained within a second rigid, sealed, watertight container. Add sufficient absorbent to the second container to take up contents of the first container in case of leakage. Label the outer container with the universal biohazard symbol.

EHRM must approve the transport of experimentally-infected animals that are removed from the animal facility. When transporting infected animals between the animal facility and the laboratory, place them in cages fitted with filter bonnets and transport them on carts with sides. Outer containers and/or animal cages must be labeled with the universal biohazard symbol.

2. Extramural Transport and Permitting

The packaging and shipping of biological materials for extramural transport must comply with federal and international shipping requirements. It is the intent of the regulations that biological material which may contain infectious agents will be packaged and shipped in such a way that the contents will not leak and will arrive in good condition. The shipper (i.e., person with direct knowledge of what is being shipped) must be trained every 2 years and be familiar with the most current packaging and shipping requirements. Consult the EHRM Manual for the Shipment of Biological Materials and Dry Ice for guidance in the packaging and shipping of diagnostic specimens, biological and infectious substances, import and export of biological materials and live organisms, and resources for appropriate forms and supplies.

G. Permits

Import/Export of Etiologic Agents

Importation of infectious materials, etiologic agents and vectors that may contain them is governed by federal regulation. In general, an import permit is required for any infectious agent known to cause disease in man. This includes but is not limited to bacteria, viruses, rickettsia, parasites, yeasts and molds. In some instances, an agent suspected of causing human disease also requires a permit.

The following vectors require import permits:

1. Animals known or suspected of being infected with any disease transmissible to man. Importation of turtles less than 4 inches in shell length and all nonhuman primates requires an importation permit issued by the CDC, Division of Global Migration and Quarantine.
2. Biological materials: Unsterilized specimens of human and animal tissue (including blood), body discharges, fluids, excretions or similar material, when known or suspected to be infected with disease transmissible to man.
3. Insects: Any living insect or other living arthropod, known or suspected of being infected with any disease transmissible to man. Also, if alive, any fleas, flies, lice, mites, mosquitoes or ticks, even if uninfected. This includes eggs, larvae, pupae, and nymphs as well as adult forms.
4. Snails: Any snails capable of transmitting schistosomiasis. No mollusks are to be admitted without a permit from either CDC or the Department of Agriculture. Any shipment of mollusks with a permit from either agency will be cleared immediately.
5. Bats: All live bats require an import permit from the CDC and the U.S. Department of Interior, Fish and Wildlife Services (202) 358-2095

When an etiologic agent, infectious material or vector containing an infectious agent is being imported to the United States it must be accompanied by an importation permit issued by the US Public Health Service (USPHS). Importation permits are issued only to the importer, who must be located in the United States. The importation permit, with the proper packaging and labeling, will expedite clearance of the package of infectious materials through the USPHS Division of Quarantine and release by U.S. Customs.

The importer is legally responsible to assure that foreign personnel package, label, and ship material in accordance with CDC and IATA regulations. Shipping labels, permit number, packaging instructions and the permit expiration date are also issued to the importer with the permit. For more information refer to the EHRS Manual for the Shipment of Biological Products, Diagnostic Specimens, Infectious Substances, Genetically-modified Materials & Dry Ice.

Instead of an importation permit, a Letter of Authorization may be issued by the issuing officer after review of an "Application to Import an Etiological Agent". The letter is issued for materials that are judged to be noninfectious, but which might be construed to be infectious by U. S. Customs inspection personnel. Letters of Authorization may be issued for items such as formalin fixed tissues, sterile cell cultures, clinical materials such as human blood, serum, plasma, urine cerebrospinal fluid, and other tissues or materials of human origin when there is no evidence or indication that such materials contain an infectious agent. Letters of Authorization are in effect for two years, and do not require a shipping label to be issued by CDC.

Importation permits and Letters of Authorization are issued by the Biosafety Branch, Office of Health and Safety, CDC, after review of a completed application form. Application forms are available online or may be obtained directly from EHRS (215) 898-4453 or by calling CDC at (404) 498-1600. Completed forms may be returned to CDC by mail (1600 Clifton Road NE, Mailstop E-79 Atlanta, GA 30333) or FAX (404) 498-2275. Application to CDC for the importation permit should be made 10 working days in advance of the shipment date to allow time for processing, issuance and delivery of the permit and shipping labels to the permittee.

Other Permits:

U.S. Department of Agriculture (USDA) Animal and Plant Health Inspection Service (APHIS) permits are required to import or transport infectious agents of live stock and biological materials containing animal, particularly livestock, material. Tissue (cell) culture techniques customarily use bovine material as a stimulant for cell growth. Tissue culture materials, and suspensions of cell culture grown viruses or other etiologic agents containing growth stimulants of bovine or other livestock origin are, therefore, controlled by the USDA due to the potential risk of introduction of exotic animal disease into the U. S. Applications for USDA/APHIS permits may be obtained online or from EHRS (215) 898-4453. Further information may be obtained by calling the USDA/APHIS at (301) 734-3277.

Export of infectious materials may require a license from the Department of Commerce. Call (202) 512-1530 for further information.

Table 1
Summary of Recommended Biosafety Levels for Infectious Agents
Complete descriptions of Biosafety Levels can be found in the
Biosafety in Microbiological and Biomedical Laboratories (BMBL) 4th Edition
(<http://www.cdc.gov/od/ohs/biosfty/bmbl4/bmbl4s3.htm>)

BSL	Agents	Practices	Safety Equipment (Primary Barriers)	Facilities (Secondary Barriers)
1	Not known to consistently cause disease in healthy adults	Standard Microbiological Practices	None required	Open bench top sink required
2	Associated with human disease, hazard: percutaneous injury, ingestion, mucous membrane exposure	BSL-1 practice plus: Limited access Biohazard warning signs "Sharps" precautions Biosafety manual defining any needed waste decontamination or medical surveillance policies	Primary barriers: Class I or II BSCs or other physical containment devices used for all manipulations of agents that cause splashes or aerosols of infectious materials; PPEs: laboratory coats; gloves; face protection as needed	BSL-1 plus: Autoclave available
3	Indigenous or exotic agents with potential for aerosol transmission; disease may have serious or lethal consequences	BSL-2 practice plus: Controlled access Decontamination of all waste Decontamination of lab clothing before laundering Baseline serum	Primary barriers: Class I or II BSCs or other physical containment devices used for all open manipulations of agents; PPE: protective lab clothing; gloves; respiratory protection as needed	BSL-2 plus: Physical separation from access corridors Self-closing, double-door access Exhausted air not recirculated Negative airflow into laboratory
4	Dangerous/exotic agents which pose high risk of life-threatening disease, aerosol-transmitted lab infections; or related agents with unknown risk of transmission	BSL-3 practices plus: Clothing change before entering Shower on exit All material decontaminated on exit from facility	Primary barriers = All procedures conducted in Class III BSCs or Class I or II BSCs <u>in combination with</u> full-body, air-supplied, positive pressure personnel suit	BSL-3 plus: Separate building or isolated zone Dedicated supply and exhaust, vacuum, and decon systems Other requirements as described in BMBL

Table 2
Summary of Recommended Biosafety Levels for Activities in Which Experimentally or Naturally Infected Vertebrate Animals Are Used
Complete descriptions of Animal Biosafety Levels can be found in the Biosafety in Microbiological and Biomedical Laboratories (BMBL) 4th Edition (<http://www.cdc.gov/od/ohs/biosfty/bmbl4/bmbl4s4.htm>)

BSL	Agents	Practices	Safety Equipment (Primary Barriers)	Facilities (Secondary Barriers)
1	Not known to consistently cause disease in healthy human adults.	Standard animal care and management practices, including appropriate medical surveillance programs	As required for normal care of each species.	Standard animal facility No recirculation of exhaust air Directional air flow recommended Handwashing sink recommended
2	Associated with human disease. Hazard: percutaneous exposure, ingestion, mucous membrane exposure.	ABSL-1 practices plus: Limited access Biohazard warning signs Sharps precautions Biosafety manual Decontamination of all infectious wastes and of animal cages prior to washing	ABSL-1 equipment plus primary barriers: containment equipment appropriate for animal species; PPES: laboratory coats, gloves, face and respiratory protection as needed.	ABSL-1 facility plus: Autoclave available Handwashing sink available in the animal room. Mechanical cage washer used
3	Indigenous or exotic agents with potential for aerosol transmission; disease may have serious health effects.	ABSL-2 practices plus: Controlled access Decontamination of clothing before laundering Cages decontaminated before bedding removed Disinfectant foot bath as needed	ABSL-2 equipment plus: Containment equipment for housing animals and cage dumping activities Class I or II BSCs available for manipulative procedures (inoculation, necropsy) that may create infectious aerosols. PPE: appropriate respiratory protection	ABSL-2 facility plus: Physical separation from access corridors Self-closing, double-door access Sealed penetrations Sealed windows Autoclave available in facility
4	Dangerous/exotic agents that pose high risk of life threatening disease; aerosol transmission, or related agents with unknown risk of transmission.	ABSL-3 practices plus: Entrance through change room where personal clothing is removed and laboratory clothing is put on; shower on exiting All wastes are decontaminated before removal from the facility	ABSL-3 equipment plus: Maximum containment equipment (i.e., Class III BSC or partial containment equipment in combination with full body, air-supplied positive-pressure personnel suit) used for all procedures and activities	ABSL-3 facility plus: Separate building or isolated zone Dedicated supply and exhaust, vacuum and decontamination systems Other requirements as described in BMBL